

General View

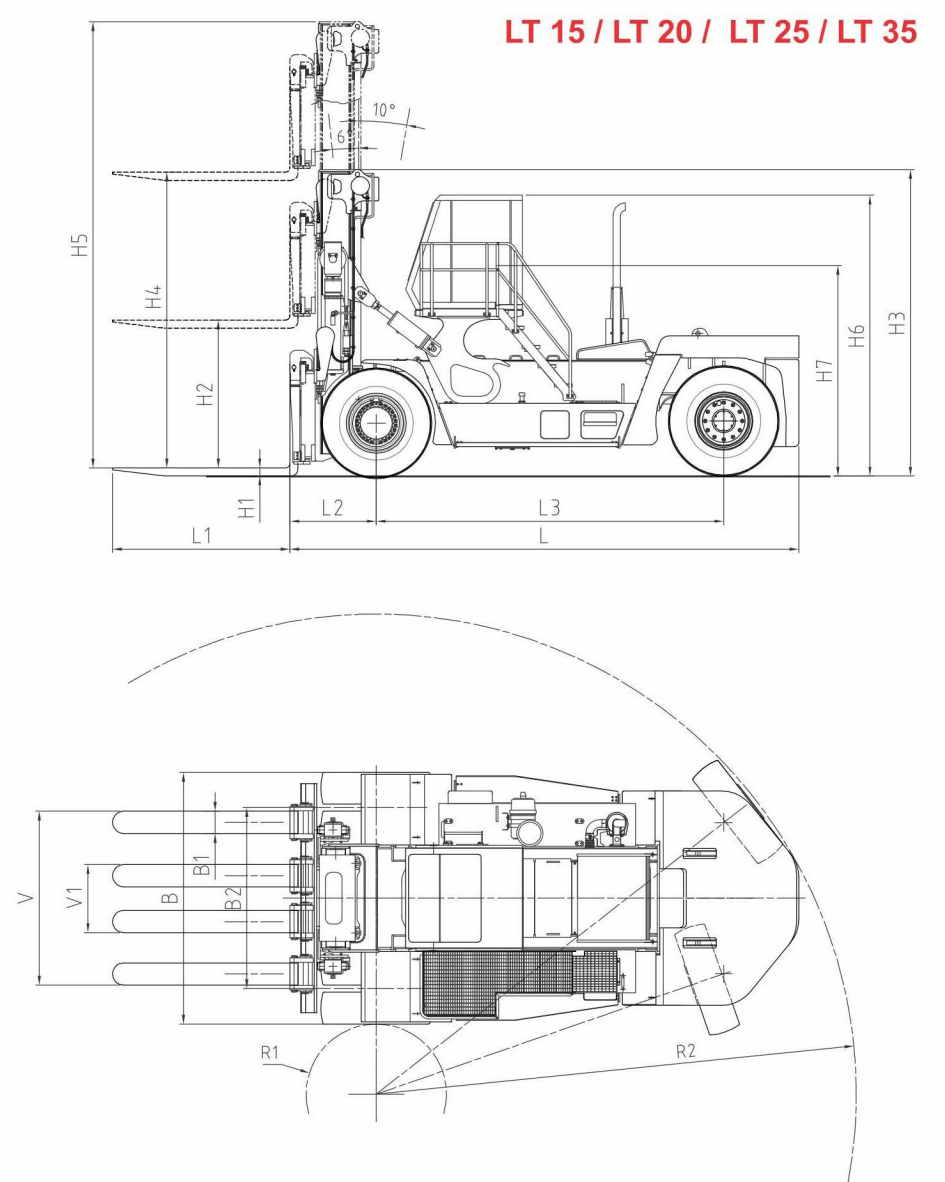
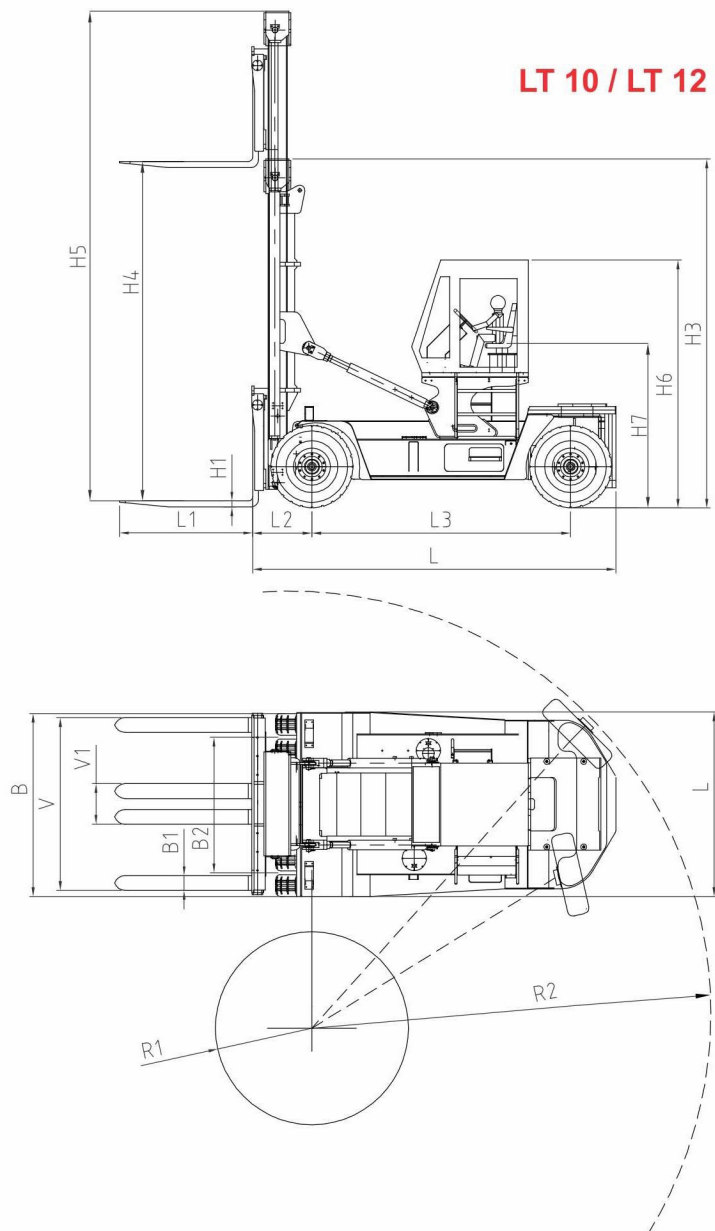

All dimensions are in mm

DIMENSIONS

| SL.NO. | DIMENSION | | UNIT | LT-10 | LT-12 | LT-15 | LT-20 | LT-25 | LT-35 |
|--------|--------------------------|----|------|-------|-------|-------|-------|-------|-------|
| 1 | FORK THICKNESS | H1 | mm | 80 | 80 | 110 | 110 | 110 | 110 |
| 2 | FREE LIFT | H2 | mm | NO | NO | 2000 | 2000 | 2000 | 2000 |
| 3 | CLOSED HEIGHT- ZERO LIFT | H3 | mm | 3720 | 4720 | 3845 | 3945 | 4045 | 4145 |
| 4 | LIFT HEIGHT | H4 | mm | 4000 | 6000 | 4000 | 4000 | 4000 | 4000 |
| 5 | CLOSED HEIGHT- MAX LIFT | H5 | mm | 5720 | 7720 | 5845 | 5945 | 6045 | 6145 |
| 6 | HEIGHT | H6 | mm | 2945 | 2945 | 3245 | 3245 | 3800 | 3800 |
| 7 | HEIGHT | H7 | mm | 2030 | 2030 | 2230 | 2330 | 2800 | 2800 |
| 8 | LENGTH | L | mm | 4950 | 5200 | 5727 | 6154 | 6585 | 6885 |
| 9 | FORK LENGTH | L1 | mm | 1800 | 1800 | 2400 | 2400 | 2400 | 2400 |
| 10 | LENGTH | L2 | mm | 900 | 900 | 1102 | 1102 | 1169 | 1169 |
| 11 | WHEEL BASE | L3 | mm | 3250 | 3500 | 3750 | 4250 | 4400 | 4700 |
| 12 | TURNING RADIUS | R1 | mm | 400 | 450 | 575 | 625 | 800 | 950 |
| 13 | TURNING RADIUS | R2 | mm | 4200 | 4600 | 5400 | 5650 | 6000 | 6495 |
| 14 | WIDTH | B | mm | 2470 | 2470 | 2470 | 2510 | 2850 | 3402 |
| 15 | FORK WIDTH | B1 | mm | 200 | 200 | 250 | 250 | 300 | 300 |
| 16 | TRACK | B2 | mm | 1788 | 1788 | 1788 | 1868 | 2450 | 2450 |
| 17 | FORK -MAX | V | mm | 2170 | 2170 | 2270 | 2270 | 2352 | 2352 |
| 18 | FORK-MIN | V1 | mm | 500 | 500 | 850 | 850 | 1220 | 1220 |

