

Sr. No - 3 voltas forklift



**VOLTAS**  
MATERIAL HANDLING

## HEAVY DUTY FORKLIFT TRUCK

**HIGHER RELIABILITY**  
**HIGHER PERFORMANCE**  
**HIGHER PRODUCTIVITY**

Capacity : 8000 Kgs @ 600 mm LC

**BS III  
Engine**



### ENGINE

Powered by a fuel efficient, four cylinder, charge air cooler direct injection, turbo charge water cooled, industrial diesel engine. Air filtration is done through a dry type air cleaner. Vertical exhaust system ensures hot exhaust gases are discharged well above the seating level. Bharat Stage III compliant four cylinder engine is used.

### TRANSMISSION

Power shift transmission with constant mesh gearing provides for standard forward and reverse speeds. Direction control and range selection are effected by a mechanical shift. Separate levers for direction and range selection provided for mechanical gear shifting.

### BRAKES

Air operated brakes are self energizing. Brakes are directly on drive wheels and are operated by a pneumatic unit for high braking force and low pedal effort. Cowl mounted and pneumatically operated parking brake.

### HYDRAULIC SYSTEM AND CONTROLS

A large size Hydraulic tank is fitted with a breather. It is used for releasing the gases formed. Gear type direct driven hydraulic pump is mounted on the transmission housing. Relief valve protects system against excessive pressures from overload. System is continuously filtered by intake suction and return line filters.



SPECIFICATIONS				
GENERAL	1	MANUFACTURER		VOLTAS
	2	MODEL		DVX 806
	3	CAPACITY	LIFTING LOAD	KG 8000
	4	LOAD CENTER	DISTANCE	MM 600
	5	POWER UNIT	ENGINE TYPE	DIESEL
	6	TYRES	PNEUMATIC (P), CUSHION (C)	P-STD / C-OPT
DIMENSIONS	7	LIFT HEIGHT STD MAST	MAX FORK HEIGHT	h3 MM 3050
	8		FREE LIFT WITH STD HVM MAST	h2 MM NIL
	9	FORK CARRIAGE	ISO CLASS	BAR
	10	FORK DIMENSIONS	THICKNESS(th) X WIDTH(W) X LENGTH(L)	MM 65 X 150 X 1220
	11	FORK SPREAD	MINIMUM - MAXIMUM	MM 650 / 1650
	12	TILT ANGLE WITH HVM	FORWARD / BACKWARD	F / B DEG 6 / 10
	13		LENGTH TO FACE OF FORKS	L2 MM 4030
	14		OVERALL WIDTH	b1 MM 2080
	15	OVERALL DIMENSIONS	HEIGHT WITH COLLAPSED MAST	h1 MM 2540
	16		HEIGHT WITH EXTENDED MAST & LBR	h4 MM 4260
PERFORMANCE	17		HEIGHT OF CANOPY GUARD	h6 MM 2400
	18	TURNING RADIUS		Wa MM 3620
	19	FRONT OVERHANG	X	MM 650
	20		TRAVEL - LADEN / UNLADEN	KMPH 25 / 30
	21	SPEEDS WITH STD HVM	LIFTING - LADEN / UNLADEN	MM/S 280 / 290
	22		LOWERING - LADEN / UNLADEN	MM/S 380 / 340
	23	GRADABILITY**	LADEN	% 17
	24	STEERING TYRE	POWER STEERING	FULL POWER
	25	WEIGHT	LADEN / UNLADEN	KG 17650 / 9650
	FRAME & TYRES	26		No - FRONT / REAR
27		TYRES	SIZE - FRONT	7.50 x 16 - 12PR
28			SIZE - REAR	7.50 x 16 - 12PR
29		WHEEL BASE	Y	MM 2500
30		TRACK	b10 / b11	MM 1940 / 2060
DRIVE	31	GROUND CLEARANCE	UNDER FRAME	m2 MM 220
	32	BRAKES	SERVICE	PNEUMATIC
	33		PARKING	PNEUMATIC
	34		MANUFACTURER / MODEL	REPUTED
	35	ENGINE	RATED HP AS PER IS 10000	HP 96
36	RATED RPM		RPM 2200	
37	RATED TORQUE		KGM 37.5 @ 1400 RPM	
38		MAKE / MODEL	INDIGENOUS	
39	TRANSMISSION	TYPE	POWERSHIFT	
40		NO OF SPEEDS	2 / 2	
41		GEAR SHIFT	MECHANICAL	

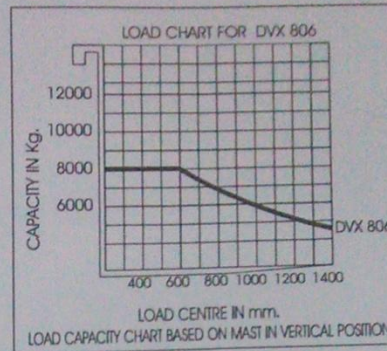

\*\*UNLADEN GRADABILITY IS LIMITED TO SKIDDING OF TYRES. SAFETY : TRUCK CONFORMS TO STABILITY REQUIREMENT AS PER 'BIS' & 'ISO' STANDARDS ALL SPECIFICATIONS ARE SUBJECT TO +/- 12% TOLERANCE APART FROM THOSE GOVERNED BY BIS. DUE TO CONTINUOUS DESIGN IMPROVEMENTS THE SPECIFICATIONS ARE SUBJECT TO CHANGE WITHOUT NOTICE. CONTACT MHB SALES OFFICE FOR APPLICATIONS INVOLVING SIDESHIFTER / FORK POSITIONER OR ANY OTHER ATTACHMENTS.

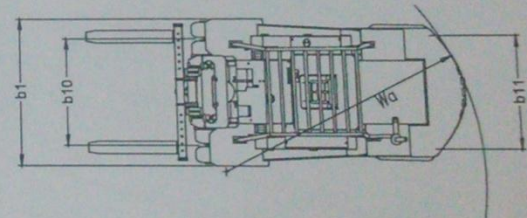
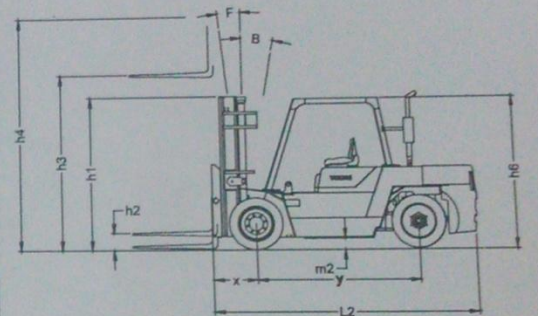

The specifications are subject to change without prior notice. Please contact our nearest office for latest specifications



**Voltas Material Handling Private Limited**

**Plant I :** Voltas Limited, Unit III, 2nd Pokhran Road, Thane West - 400 601, Maharashtra  
Ph: 91-22-67920252 / 231/201/221/366  
Fax : 91-22-67920164 / 117  
e-mail : enquiries.vmh@voltas-mh.com

**Plant II :** 5/4 Chandan Nagar, Pune-Nagar Road, Pune, 411014, Maharashtra

Visit us: [www.voltas-mh.com](http://www.voltas-mh.com)

**For Export Enquires :**

Tel.: 91-22-67920119 / 205  
e-mail: sameer.kalamdani@voltas-mh.com

F3MKT/MH/302/131/00

#### BRANCHES / AREA OFFICES

Ahmedabad Tel.: 079-66306601 ● Bangalore Tel.: 080-67132538/ 39/ 42  
Bhubneshwar Mob.: 9178737311 ● Chandigarh Tel.: -0172-6610132 / Mob. 9216223028  
Chennai Tel.: 044-66760321 / 23 ● Coimbatore Mob.: 8220000370  
Hyderabad Tel.: 040-66746820 / 21 / 22 ● Jaipur Tel.: 0141-6541013 / Mob. 9799393454  
Jamshedpur Tel.: 0657 - 6518804 / 2424276 ● Kochi Tel.: 0484 - 6605508 / 2359624  
Kolkata Tel.: 033 - 66266323 / 25 ● Mumbai Tel.: 022-67920125 ● Nagpur Tel.: 0712-6454868  
New Delhi Tel.: 011-66505511 / 12 / 13 ● Pune Tel.: 020 - 66046614 ● Vizag Tel.: 0891-2754665

#### DEALERS

Ahmedabad Tel.: 079-26301778/79 ● Aurangabad Tel.: 0240-6615425 / 6 / 7 / 8 Mob. 9657722566  
Bangalore Tel.: 080-26672350 / Mob.: 09449857458 ● Bhubaneshwar Tel.: 0674 - 2570142 / 6531278  
Hyderabad Tel.: 040-66662996 / Mob. 9848114459 ● Chandigarh Mob: 9530601175  
Coimbatore Tel.: 0422-2565977 ● Delhi Tel.: 0129-4274444 ● Goa Tel.: 0832-2313967 / 9850471387  
Guwahati Mob.: 9435146562 ● Hubli Tel.: 0836-2271164 / Mob. 09482233151  
Indore Tel.: 0731-4041373 / Mob. 9826052942 ● Jaipur Mob. 9414157442  
Jamshedpur Tel.: 0657-2202785 / 6 / 65440226 ● Kochi Tel.: 0484-2395911 / 4081040  
Kolkata Mob. 9830086288 ● Madurai Tel.: 0452-2371473 / Mob. 9500918250  
Mumbai Tel.: 022-27704917 / 8888851215 ● Nagpur Mob.: 9763728136  
Pune Tel.: 020-46782227 / 8 / 9 Mob. 9922996271 ● Vapi Tel.: 0260-2425143 / Mob. 9978901772